

# Technical Manual

# IRS Sigma



## ACOUSTIC & ELECTRICAL SPECIFICATIONS:

- Nominal Impedance: 4Ω
- Max Amp Power: 500 watts\*
- Frequency Response: 30 Hz - 42,000Hz (± 2dB)
- Sensitivity: 87dB (1 watt @ 1 meter)
- Crossover Frequency: 160Hz, 600Hz, 3800Hz

## SYSTEM COMPONENTS:

- Cabinet: IRS Sigma (Not for Sale)
- Front Grille, w/logo: A026-7280
- Lower Rear Grille: A026-7354
- Upper Rear Grille: A026-7086
- Low-Frequency Transducer: 12" (304mm) Woofer (902-7502), 330709-001
- DC Resistance: 3.7 ohms ± 10%
- Mid-Bass Transducer: 6 1/2" (165mm) Mid-Bass Coupler (902-7379)
- DC Resistance: 3.6 ohms ± 10%
- Mid Frequency Transducer: Neodymium Emim (902-5339A)
- DC Resistance: 3.7 ohms ± 10%
- High-Frequency Transducer (2): Emit-B Neodymium (902-5228)
- DC Resistance: 3.9 ohms ± 10%

## • Crossover Network

- Input Assembly (A017-7399)
- Woofer Network/Board (A015-7398)
- Mid-Bass PCB (A020-7397)
- Tweeter/Midrange PCB (A020-7396)

## AURAL SWEEP TEST SPECIFICATIONS:

- System Aural Sweep Test: 6.0V Input 30 Hz to 42 kHz
- L.F. Aural Sweep Test: 6.0V Input 30 Hz to 500 Hz
- M.B. Aural Sweep Test: 5.0V Input 100 Hz to 1 kHz
- M.F. Aural Sweep Test: 4.0V Input 500 Hz to 4 kHz
- H.F. Aural Sweep Test: 2.83V Input 3 kHz to 42 kHz

## PHYSICAL SPECIFICATIONS:

- Enclosure dimensions: 58 1/4" x 18 1/2" x 16-1/4" (H x W x D) (1422 x 457 x 406mm)
- Weight: 195 lbs (88.6 kg) Each

## WARRANTY:

- Refer to Warranty Statement packed with each product.

\* The maximum recommended amplifier power rating will ensure proper system headroom to allow for occasional peaks. We do not recommend sustained operation at these maximum power levels.

## PACKING

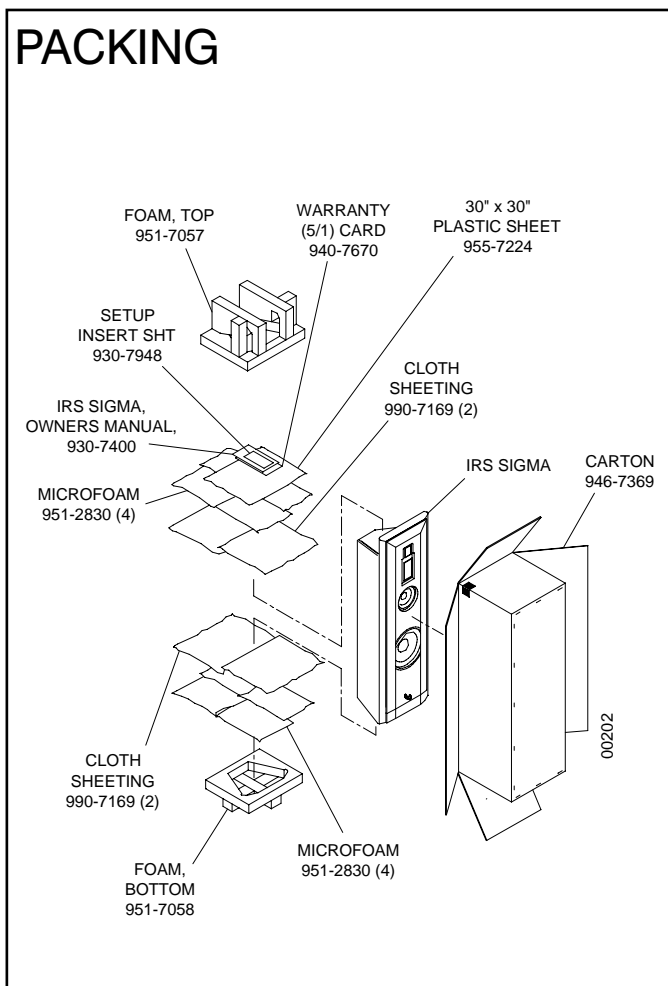

## SWITCHBOARD PCB SCHEMATIC

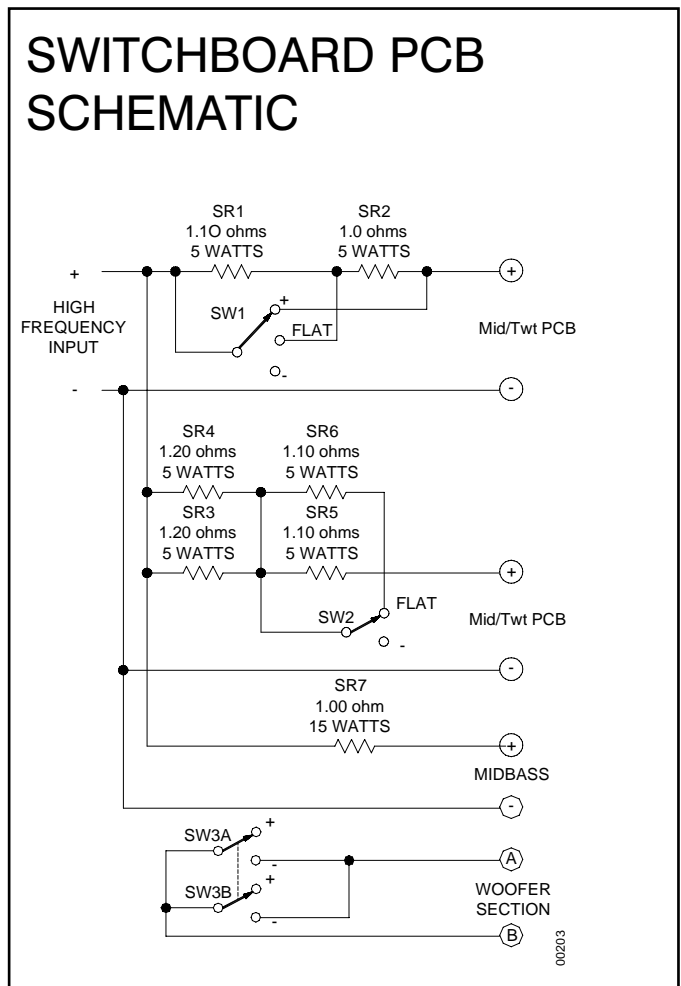

IRS Sigma

# Technical Manual

# IRS Sigma



## WIRING DIAGRAM

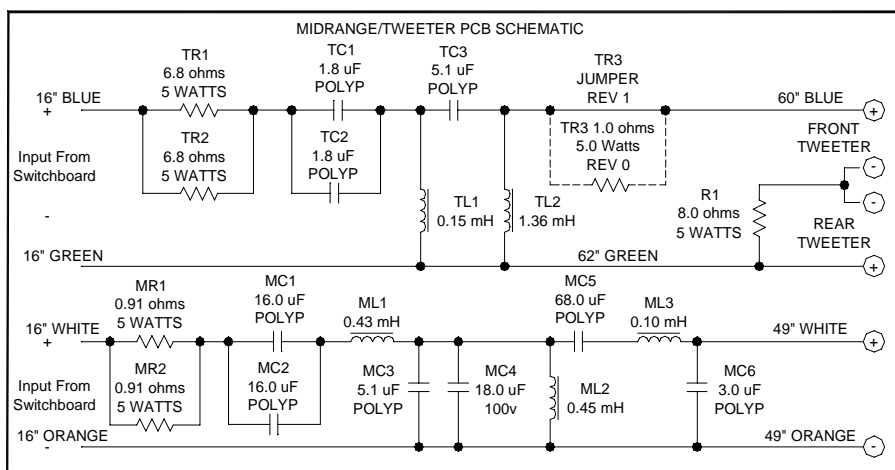
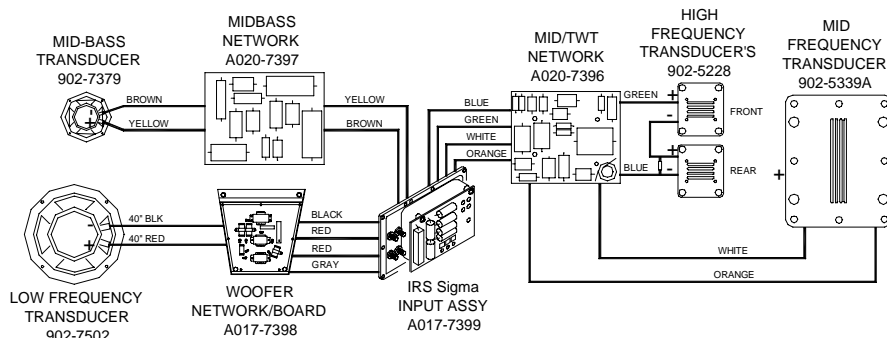

H.F.

M. F.

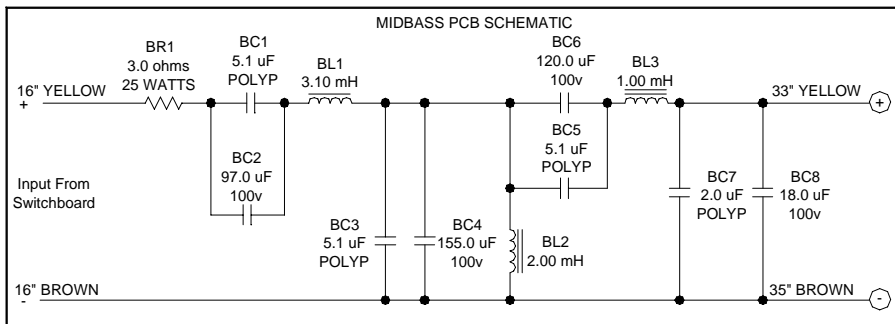

M.B.F.

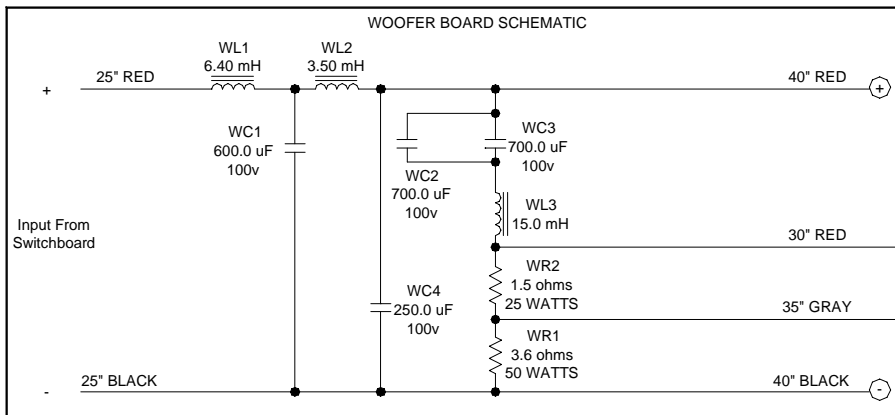

L.F.

(A)  
TO SWITCH BOARD

(B)

00204

**IRS Sigma**

# Technical Manual

# IRS Sigma



## EXPLODED VIEW

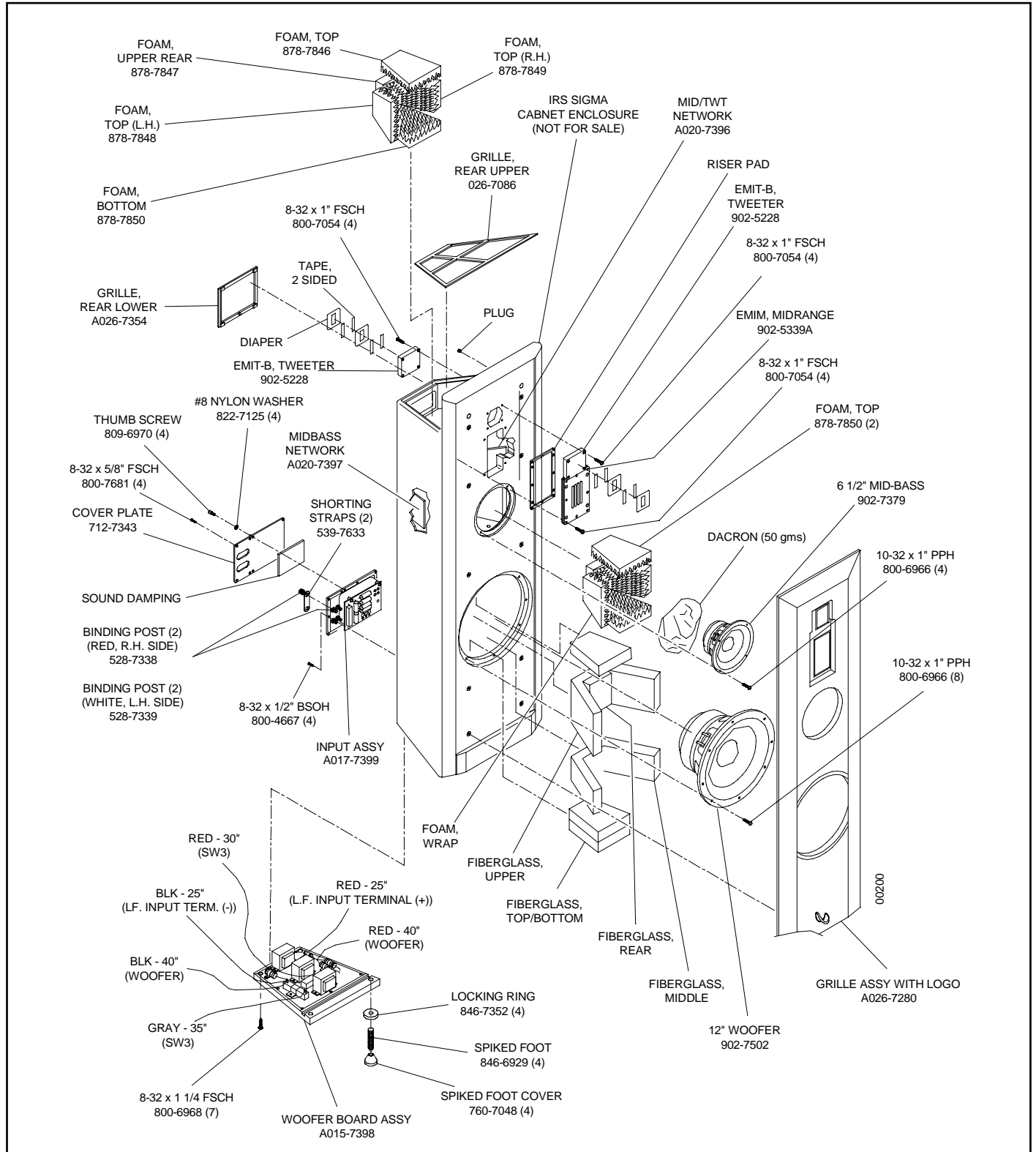

**IRS Sigma**